



4-Channel DMX512 Decoder



SKU: DMX-4CH-8A

Product Data

Input Voltage	Output Power	Output Current	Size
12-48V DC	384W (12V) 768W (24V)	8A/4 Channels	L: 6.5" (165 mm) W: 2.7" (70 mm) H: 1.5" (37 mm)

4-Channel DMX512 Decoder

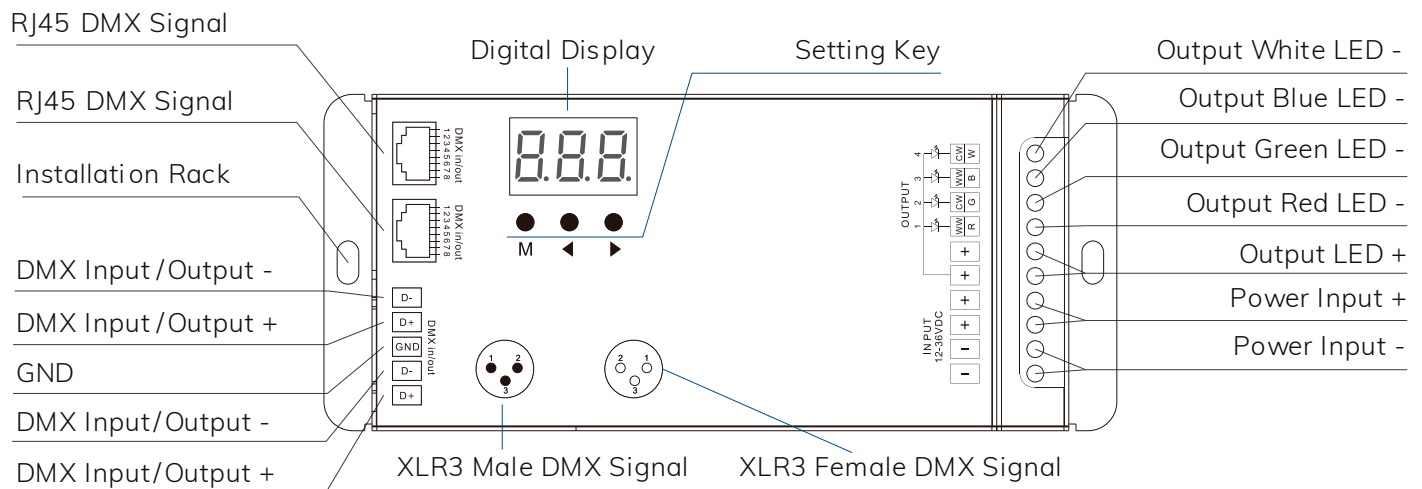

Product Features

- High-end DMX512 & RDM LED Decoder.
- Controller mode available for standalone RGB control.
- User-friendly digital display.
- Durable metal casing.
- 8 amp, 4-channel constant voltage output.
- Multiple data port options: XLR3 ports, RJ45 ports, and screw DMX terminals.
- Compatibility with DMX512, DMX512 (1990), DMX512-A and RDM V1.0 (E1.20 - 2006 ESTA Standard) protocols.
- RDM bi-directional communication function allowing for real time remote monitoring.
- Short circuit protection.
- **Under Controller Mode**
 - 10 levels of brightness, 8 levels of speed.
 - 30 built-in programs for RGB and RGBW static and dynamic patterns.
 - Different speed levels and individual channel control.
- **Under Decoder mode:**
 - Decoder detection, DMX address setting, and decoder information display functions.
 - Address up to four channels.
 - PWM output frequency setting.
 - PWM ratio frequency setting.
 - Optional decoding modes, brightness adjustments, Gamma-dimming curve values setting.

Wiring

01. Confirm that the power supply voltage matches the LED voltage and that the power supply is unplugged.
02. Connect the LEDs and power supply using the screw terminals. Power supply positive and negative should be connected to “V+” and “V-” terminals under DC power input, respectively. LED positive should be connected to the “+” terminal. Connect LED negatives to output channels.
03. Power up the power supply.
04. Connect the DMX input and output (if applicable) to any of the input/output ports. Note: Do not send DMX signals to the decoder while it is powered down.

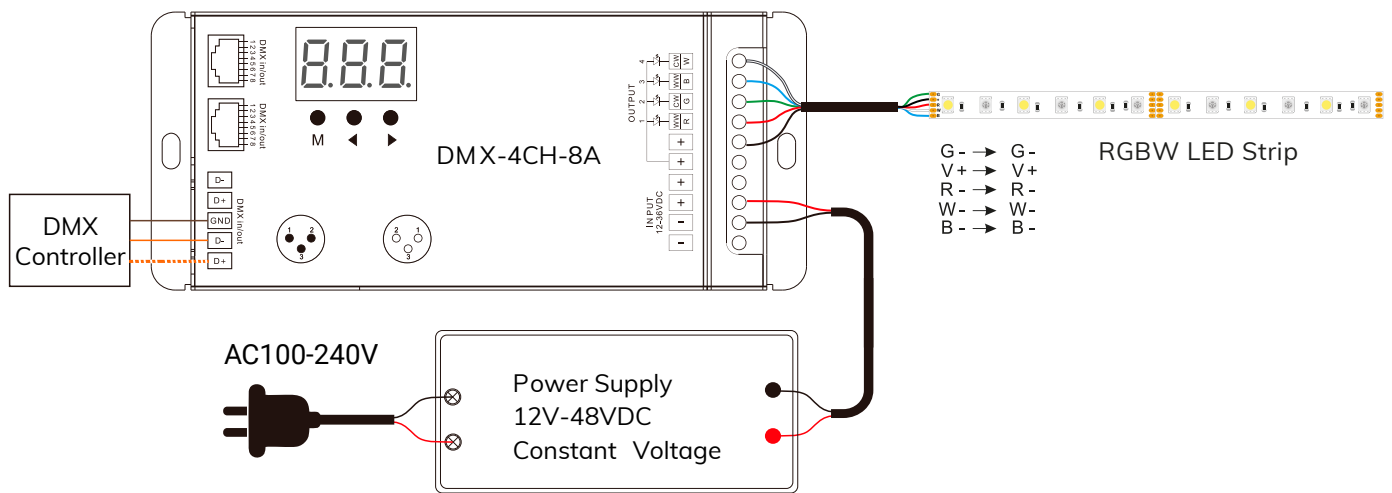

Operation

Before you change any other settings, please determine whether you would like the device to be in Controller or Decoder mode. If you would like to use the device as a Decoder, simply hook it up to a DMX Controller. When no DMX signal is received, the unit will automatically revert to its standalone Controller mode.

DMX Controller Mode

The standalone mode of the unit features both pre-programmed modes as well as individual channel control for RGB and RGBW light fixtures. These are the functions available:

Pre-Programmed RGB/RGBW Modes P01

Controls a total of 30 programs. The static and dynamic modes use the first three channels and assign values based on the assumption that Channel 1 is controlling red, Channel 2 is controlling green and Channel 3 is controlling blue. Press M and then Left or Right to select between preset modes when in the menu labeled P01-P30.

Brightness Control b - F

This option controls the brightness of the programmed scenes. Press M for 3 seconds within a program and then short press M until you see the display that starts with a lowercase B. Then press Left or Right to select a brightness level between 1 and F with F being the brightest setting.

Speed Control S - 8

This option controls the brightness of the programmed scenes. Press M for 3 seconds within a program and then short press M until you see the display that starts with a lowercase B. Then press Left or Right to select a brightness level between 1 and F with F being the brightest setting.

RGB Mode List

No.	Name	No.	Name	No.	Name
P01	Static Red	P11	Green Strobe	P21	Red Yellow Smooth
P02	Static Green	P12	Blue Strobe	P22	Green Cyan Smooth
P03	Static Blue	P13	White Strobe	P23	Blue Purple Smooth
P04	Static Yellow	P14	RGB Strobe	P24	Blue White Smooth
P05	Static Cyan	P15	7 Color Strobe	P25	RGB+W Smooth
P06	Static Purple	P16	Red Fade in and out	P26	RGBW Smooth
P07	Static White	P17	Green Fade in and out	P27	RGBY Smooth
P08	RGB Jump	P18	Blue Fade in and out	P28	Yellow Cyan Purple Smooth
P09	7 Color Jump	P19	White Fade in and out	P29	RGB Smooth
P10	Red Strobe	P20	RGBW Fade in and out	P30	6 Color Smooth

White Channel Control

4FF

This option controls the brightness of the White channel (Output 4) if you intend to use that channel in standalone mode. Press M for 3 seconds within a program and then short press M until you see the display that starts with 4. Then press Left or Right to select a speed level between 401 and 4FF with 4FF being the fastest setting. The steps within this setting represent 0-255 steps of brightness.

Individual Channel Control

L-1

If you don't want to use a pre-programmed scene, you can also use the controller mode to control each channel individually. Short press M until you are in the display that starts with L. Select a channel of 1 through 4 by pressing M for 3 seconds until a display is shown that starts with the numbers 1-4. The first number is the channel and the next set of characters indicates the brightness level. Press the Left and Right buttons to select a setting between 00-FF, with "FF" indicating 100% output. (For example, Channel 2 and 100% brightness would be 2FF on the display.) The steps within this setting represent 0-255 steps of brightness. Let the buttons timeout when the desired brightness level is reached.

DMX Decoder Mode**Decoder DMX Menu Options**

001

When the display is showing 001 then you are in DMX Mode. Within this mode you are able to access different advanced settings on the decoder.

Set Up**Basic Functions****DMX Address:**

Most users will only need to adjust the address on their decoders. This menu function indicates the current DMX address. Press M and then Left or Right to change the DMX address. Channel 1 represents Red, Channel 2 represents Green, Channel 3 represents Blue and Channel 4 represents White. If your decoder is not receiving a DMX signal, the display will blink with dashes until a signal is sent to the unit. If a DMX signal is present the unit will enter decoder mode automatically.

Advanced Functions

DMX Channel Setting: The "Output Channels" parameter allows the utilization of all four output channels using fewer DMX channels. To select the number of output channels (1, 2 or 4 channels) simply press M and the Left key simultaneously for 3 seconds while in DMX Mode until you see an option that starts with a lowercase D, then use the Left and Right buttons to select between d-1, d-2, or d-4. For example, when set as d-1 (1 Channel setting), the decoder will only occupy 1 DMX address and all four channels on the decoder will output the same brightness of this address. Press M for 3 seconds or let it timeout after 10 seconds to quit the setting parameter.

Grey Scale Setting: For this parameter, there are two options: 8 bit system (represented on the display as b08) or 16 bit system (represented on the display as b16). To get to this setting, press M and the Left key simultaneously for 3 seconds while in DMX Mode until you see an option that starts with b, then use the Left and Right buttons to select between b08 or b16. Choose 16 bit if the DMX controller and products supports 16 bit.

Setting the PWM Frequency: For this parameter, there are seven options: 250Hz (represented on the display as F02) and 500Hz (represented on the display as F05), 1000Hz (represented on the display as F10), 2000Hz (represented on the display as F20), 4000Hz (represented on the display as F40), 8000Hz (represented on the display as F80) or 16000Hz (represented on the display as F16). To get to this setting, press M and the Left key simultaneously for 3 seconds while in DMX Mode until you see an option that starts with F, then use the Left and Right buttons to select between the different options. Press M for 3 seconds or let it timeout after 10 seconds to quit the setting parameter. Selecting a higher PWM frequency will cause lower output current, but will be more suitable for film to reduce flicker on screen.

Setting the Dimming Curve Gamma Value: The “gamma” value of the dimming curve is set with this parameter. This unit has two dimming curve options: linear (represented on the display by C-L) and logarithmic (represented on the display by C-E). To get to this setting, press M and the Left key simultaneously for 3 seconds while in DMX Mode until you see an option that starts with C, then use the Left and Right buttons to select between C-L and C-E. Press M for 3 seconds or let it timeout after 10 seconds to quit the setting parameter.

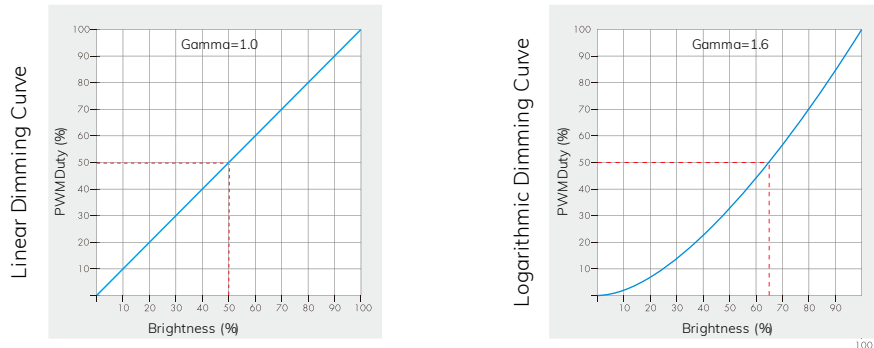

Brightness Level: This parameter allows you to change the level of brightness between 0 to 100% when there is no DMX input signal. To get to this setting, press M and the Left key simultaneously for 3 seconds while in DMX Mode until you see an option that starts with d, then use the Left and Right buttons to select between d00 and dFF. Press M for 3 seconds or let it timeout after 10 seconds to quit the setting parameter.

Blank Screen Mode: If you do not want to constantly have your unit’s display panel light on, you can use this function to enter Blank Screen Mode. To get to this setting, press M and the Left key simultaneously for 3 seconds while in DMX Mode until you see an option that starts with a lowercase B, then use the Left and Right buttons to select between bon (to turn Blank Screen Mode on) and boF (to turn Blank Screen Mode off). Press M for 3 seconds or let it timeout after 10 seconds to quit the setting parameter.

Restore Factory Settings:

Press and hold both Left and Right keys until the digital displays RES. Then release the keys and the display will turn on again, and all settings will be reset to factory settings, which are:

- DMX Address: 001
- DMX Address Quantity: 4 channel decoder mode
- PWM Frequency: High
- Gamma: Logarithmic
- Blank Screen Mode: Off

Warranty Information

Limited Warranty

This product has a 5 year limited warranty from the date of shipment. This warranty only includes the main product outlined in this specification sheet and does not include the additional accessories that are used as a reference. Complete warranty details for fixtures and additional accessories are available at: <https://www.evoralignt.com> within the Policies section. For warranty related questions please contact the product support team at support@evoralignt.com

Consumer’s Acknowledgment

Évoralignt stands behind its products when they are used properly and according to our specifications. When you purchase our products, you are agreeing to the terms and conditions outlined in our warranty section. We try our best to make recommendations, but the burden of proper installation, design, and maintenance relies on the purchaser. This limited warranty does not include product failures that are the result of: Not using a voltage regulated power supply to connect the LED product or controls; Connecting LED products to the wrong output voltage; Improper connection of power supplies, LED products, or controls; Connecting LED products or controls directly to any AC power source if they are stated for DC only input; Connecting power supplies backwards to an AC power source; Products used in an inappropriate location or in environmental conditions (temperature, humidity, moisture, etc.) outside the normal specified range; Water damage to products not specifically sold as waterproof products; Electrical power surges and spikes; Damage from hail, flooding, tornado, fire, wind, earthquake, lightning, electrical storm, or any other natural disasters or “force majeure” incidences; Damage caused by a vehicle or other accident; Damage caused when transporting the item; Damage to any products that were modified by the user, used for purposes other than as intended or directed, or connected to LED systems or components not purchased from Évoralignt; Products that have been subjected to misuse, mishandling, misapplication or accident. Products used in connection with any components, devices or systems other than those explicitly approved as compatible with Company’s products and listed on Company’s website. Excessive wear and tear and/or physical or accidental abuse, loss, or theft. Improper repairs or warranty services performed by someone other than Évoralignt will void this warranty.