

Satori™ Neon Side Bend LED Strip Light | Cut Sheet



Description

The Satori™ Neon Side Bend Strip Light offers fully diffused white accent lighting, ideal for upscale retail or hospitality settings. This modern rendition of the vintage glass tube glow boasts superior bending and eliminates hazards. While perfect for indoor signage, wall illumination, or recesses, it's also IP65-rated for landscaping and outdoor marquees.



7 Year Warranty

Product Features

CRI	CRI up to 83
CCT	3000K / 5000K
Voltage	24V DC Input
Lumens	Up to 155 lm/ft (510 lm/m)
Beam Angle	160° Beam Angle
Ambient Temp	-4°F to 113°F (-20°C to 45°C)
Operating Temp	-4°F to 167°F (-20°C to 75°C)
Cutting Points	2" (50 mm)
Max Run Length in Series	32 ft (10 m)
LED Size	3014
Dimmable	Yes
Environment	IP65 outdoor, wet location



Dimensions

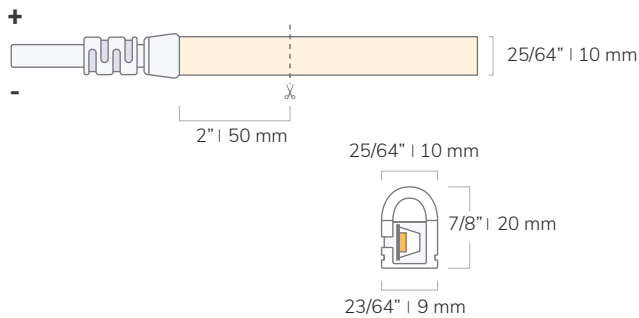

SKU Builder

Series	Side Bend	Color Temp.	Voltage	Length
NEON	S	30K - 3000K 50K - 5000K	24V	32FT

Example: NEON-S-30K-24V-32FT

Product Specifications

Product SKU	CCT	Watts/Foot	Lumens/Foot (Meter)	Luminous Efficacy Lumens/Watt	CRI	Gamut Score Rg (Color Sat.)	Relative Fidelity (Rf)	TLCI (Qa)
NEON-S-30K	3000K	2.7 W/ft (9 W/m)	144 lm/ft (473 lm/m)	52 lm/W	83	94	75	85
NEON-S-50K	5000K	2.7 W/ft (9 W/m)	155 lm/ft (510 lm/m)	56 lm/W	83	95	73	83